

A close-up photograph of the stator windings of an electric motor, showing multiple layers of copper wire coils. A large, semi-transparent yellow dollar sign is overlaid on the image, serving as a background for the text.

# 6 Ways to *Save Money* on ELECTRIC MOTORS

Energy and Cost-Efficient Solutions for Your Electric Motors

# Introduction

In a world where energy efficiency is of increasing importance, finding a way to run electric motors effectively is valuable both to the environment and to a company's bottom line. With increasingly sophisticated tools, technology and maintenance, breathing new — and more efficient — life into existing systems is easier now than ever. Minor investments can see major rewards and significant savings.

## Let's look at six ways you can save money maintaining your electric motors.

### 1. CONNECT MOTORS TO VARIABLE FREQUENCY DRIVES TO IMPROVE EFFICIENCY.

A variable frequency drive allows motor speeds to be controlled to match the demand requirements it needs to handle. The machine can shift to accommodate varying workloads without valves, dampers, and other throttling controls.

By enabling the motor's easy adjustment, these drives increase energy efficiency — the motor can perform the same tasks but do less work to accomplish them. They are especially effective in situations where drag is a key factor, and can save up to 55% in the costs of applications such as:

- HVAC systems
- Fan systems
- Centrifugal pumps

Consider your motor's applications before investing in a variable frequency drive. For gravity- or inertia-driven applications — such as cranes, displacement pumps, rolling mills, and conveyors — reducing motor speed will not save energy. In fact, these drives waste only 3 to 5% of the energy they handle, so it's important to evaluate potential savings vs. losses. Drag-driven applications, however — fans and centrifugal pumps — are more practical for VFD use. The physics of drag dictate that a small reduction in motor speed results in a significant reduction in energy consumption.

In addition to savings in maintenance and operations, many VFD's are currently part of incentive programs to encourage companies to retrofit their systems and improve energy efficiency. Check with your local power company for this information.

VARIABLE FREQUENCY DRIVE (VFD) INCENTIVES	
Motor Size on which VFD is installed (HP)	Participant Incentive (\$/VFD)
1	\$50
1.5	\$80
2	\$105
3	\$160
5	\$265
7.5	\$400
10	\$535
15	\$805
20	\$1,070
25	\$1,340
30	\$1,610
40	\$2,145
50	\$2,565
60	\$3,220
75	\$3,980
100	\$4,835

\*for new installations only

Find out if they're a good fit for your business — and how much you could save — through the [SAVEONENERGY Program](#).



## 2. PROTECT SAVINGS EVEN FURTHER WITH INDUCTIVE ABSORBERS.

Without proper protection, VFD systems can generate damaging motor bearing currents that result in:

- Frosting
- Bearing fluting
- Lubrication breakdown
- Electrical discharge machining (EDM)
- Motor bearing failure



Common mode chokes absorb these damaging currents, preventing energy and high-frequency electrical signals from flowing into circuits and creating unwanted results. Equipment reliability is maximized, time otherwise spent on machine repair is saved, and unnecessary downtime — and costs — are avoided.

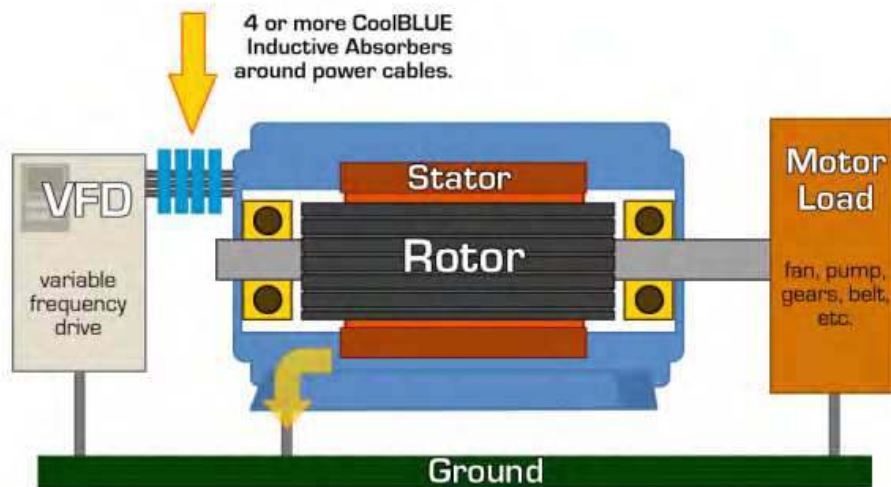

Inductive absorbers like CoolBLUE's offer exceptional VFD/motor protection solutions for a wide variety of industries. [Click here](#) for more information.

### 3. SOFT START A MOTOR FOR A MORE REGULATED, MANAGEABLE ENERGY FLOW FROM THE BEGINNING.

There are three ways to start a three-phase motor. With a hard start, all three of the motor's voltages are applied at once, in full, from a state of rest. This creates a current surge of five to seven times the full load current for the motor, and abruptly charges the motor from zero rpm to full operating speed as quickly as possible.

A soft start applies power to the motor gradually, reducing the initial surge current. While this eliminates the need for a dramatic initial charge, it takes longer for the motor to come to full speed.

During a star delta start, the motor winding is physically reconfigured to reduce voltage. During starting, the motor windings are connected in a star configuration, thus reducing the voltage across winding.

If you need to start a new motor during peak energy consumption, the soft start method may save money on your electric bill by avoiding a power spike. It also saves efficiency in the rest of your facility's operations, avoiding problems such as:

- Blown fuses and tripped breakers
- Excessive voltage drops on power feeders
- Difficulty in starting the motor
- Other facility motors stalling
- Lights dimming
- Sensitive electrical equipment malfunctions

In addition to managing electricity throughout a facility, soft starts are even more valuable for their impact on the life and performance of the motor itself. They reduce the risk of electrical, technical and mechanical problems related to excessive stress and wear to the drivetrain, mechanical stress to the load and internal thermal stress, as well. Though it cannot reduce overall motor heating, soft starts allow temperature shifts to happen gradually.

Today's solid-state soft starters use silicon controlled rectifiers, thyristors and semiconductors to control the current flow to a motor as it starts. Available in a variety of voltages and models, they can be custom fitted to a system's needs for maximum power efficiency.

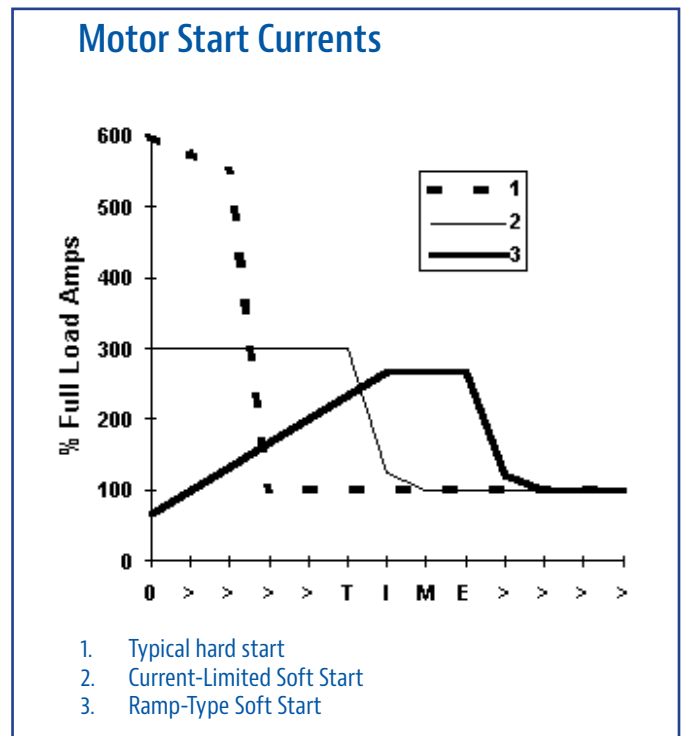

#### 4. MOTORS BLOW OUT. REWIND YOURS PROPERLY.

When your motor burns or blows out, there are two easy options: replace it, or rewind it. A new motor can be a significant investment in both cost and time, and simply may not be in your budget.

Rewinding a motor, when done correctly, allows it to run at the same operating efficiency as new. Many sources will caution against the practice of rewinding motors, claiming that it can cause harm to the motor or related systems. This is only true if the rewinding isn't handled carefully and done correctly.

— Check the [EASA guidelines](#) to maintaining motor efficiency for help.



Motor Rewinding

#### 5. MEASURE YOUR NEEDS, AND SIZE MOTORS CAREFULLY FOR THE BEST FIT.

For the best impact and efficiency, it's important to evaluate your facility and its systems as a whole. Some motors and processes demand more energy than others, while some can run slower or carry less capacity.

An old full-load motor can be highly efficient in the right application, but its load needs to be used to its maximum advantage. Even the latest technology will run inefficiently with a reduced load.

Good engineering practice dictates using a slightly oversized motor for any given application; it offers extra capacity when needed, and extends the life of the motor. However, if the difference between a motor's potential load and standard operating load is dramatically different, it wastes a lot of potential. Evaluating these systems and possibly redistributing motor power in a facility can gain overall efficiency.

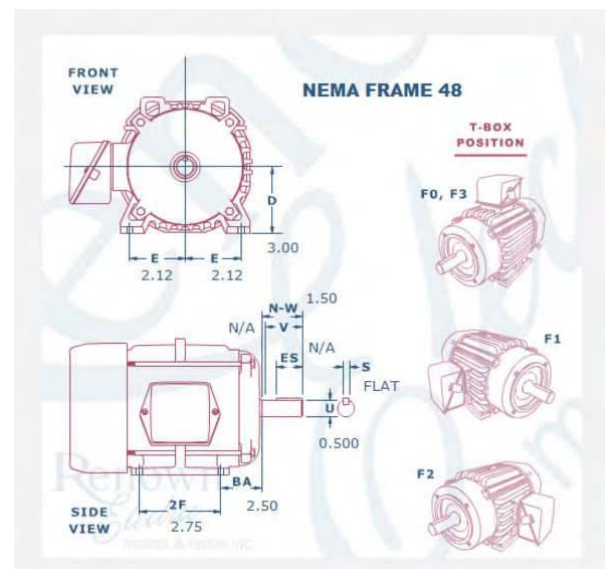

Motors and Processes

## 6. IMPLEMENT A MAINTENANCE PROGRAM TO STOP EQUIPMENT FAILURE BEFORE IT HAPPENS.

Electric motors are the heart of operations for many facilities, and their failure is costly not only in downtime and labor, but fundamentally in parts and repairs. With regular, routine maintenance programs, a motor's problems can be easily predicted and prevented, and repairs can be made preemptively during regularly scheduled downtime.

Alignment, ventilation, vibration and lubrication levels are all varying elements that contribute to the health of your electric motors. Monitoring these elements can provide security against unplanned failures, as well as adding to the efficiency and daily performance of your machine.

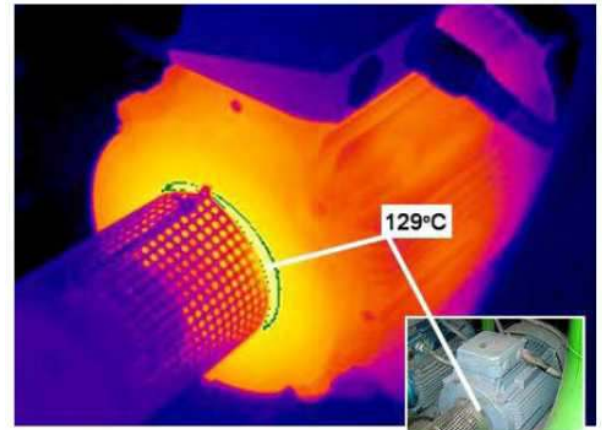

Routine Maintenance Programs that can benefit your electric motors include:

- Dynamic Balancing
- Infrared Thermography
- Laser Alignment
- Oil Analysis
- Vibration Analysis
- Winding Analysis

Many of these evaluations can be performed easily on site, and can save money on maintenance and extend your motor's life without impacting daily operations.

### COST CUTTING SERVICES WITH RENOWN ELECTRIC

With service support 24 hours a day, seven days a week, the Renown Electric Team strives to help keep your motor running at top efficiency. From maintenance programs to money-saving retrofits, Renown has worked to provide the highest quality electric motor services for the past three decades. We excel in all aspects of system service and repair — contact the team today to see how we can help you save costs on your next project.

Visit our website at [www.renown-electric.com](http://www.renown-electric.com), or [contact us](#) with any questions or for more information any time.

See How Renown Electric  
Helped a Rubber Mill  
Extend Motor Life

